

NOTES

1. Drawing in millimetres unless noted otherwise.
2. The picnic table set is used in parks and gardens across the municipality. There is a larger 3000mm long version in addition to the 2000mm version shown here.
3. The picnic set should be positioned to take advantage of summer shade, winter sun and any interesting views or activities and is ideally located near BBQ's.
4. Where practicable a recommended 1000mm (preferred 1500mm) circulation space should be provided around the entire picnic table to allow for independent movement of those using mobility aids.
5. Where a single picnic table is placed in a public space, the benches must be placed to allow wheelchair access as shown in plan view. However, where multiple picnic tables are placed, seek advice from City of Port Phillip Access and Inclusion Officers when seeking to remove the wheelchair gap. The picnic table should be positioned to take advantage of accessible paths so that the wheelchair/pram space faces directly onto footpath where practicable.
6. The frames are fabricated from grade 316 stainless steel. Bench and tabletops are clad in hardwood, recycled hardwood and composite timber battens. Benches and table are fixed in the surface using a gib key and socket detail.
7. Concrete colour to match adjacent and to be 25MPa at 28 days.
8. Battens to be approved type and material. Timber battens to be of first quality, straight grained, free of splits, gum veins or splinters. All exposed edges to have 3mm chamfer and sanded smooth. An additional coat of stain and sanding may be required after installation where instructed by council.
9. 40 x 30mm approved battens at 10mm spacings. Securely fix to 'T' and 'L' sections from rear side with 6mm screws (1 no .per connection) heads to be countersunk.
10. For fabrication and installation details contact the City of Port Phillip.
11. Where excavation will occur, contractor must conduct a Dial Before You Dig (www.1100.com.au).

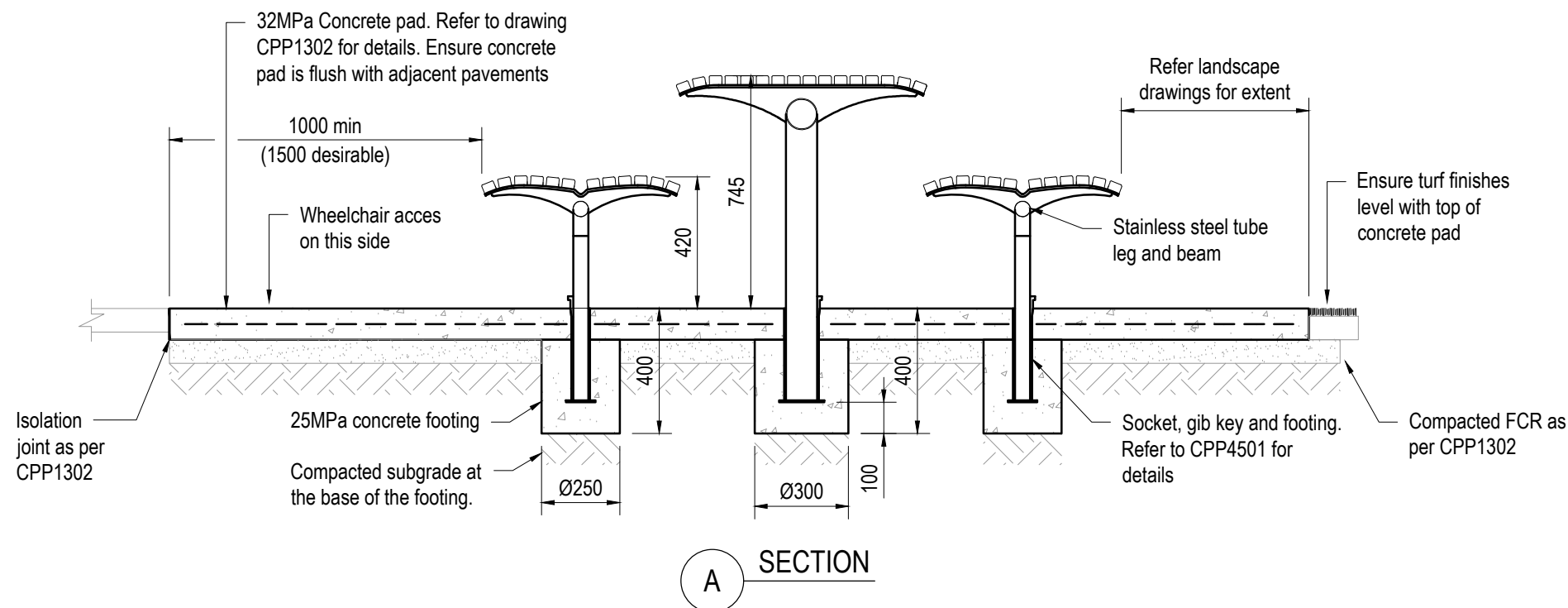

A APPROVED FOR USE		DEC 2020
No	Revision	Date

Disclaimer:

The authors and sponsoring organisations shall have no liability or responsibility to the user or any other person or entity with respect to any liability, loss or damage caused or alleged to be caused, directly or indirectly, by the adoption and use of these Standard Drawings including, but not limited to, any interruption of service, loss of business or anticipatory profits, or consequential damages resulting from the use of these Standard Drawings. Persons must not rely on these Standard Drawings as the equivalent of, or a substitute for, project-specific design and assessment by an appropriately qualified professional.



DRAWING NOT TO SCALE		Drawing Title	PICNIC TABLE - TIMBER SLATTED
Approved	Project Services	Original Size	A3
Date	Dec. 2020	Drawing No:	CPP4302
			Rev: A